

# ICMS

*Inline Condition Monitoring Sensor  
for physical fluid properties*

ICMS3-0M



## Features

- Multi-parameter monitoring:
  - Viscosity
  - Mass Density
  - Temperature
- High sensitivity and low drift
- Compact and robust design
- Easy to install
- Modbus RTU interface
- Dual programmable 4 - 20mA outputs
- High pressure option available

## Applications

- Oil condition monitoring
- Fuel quality control
- Analysis of process media
- Monitoring of mixing processes

## Description

The ICMS is a compact sensor for monitoring the mechanical fluid properties viscosity and mass density based on a low frequency resonant sensor element.

The outstanding performance of the ICMS is achieved by combining a patented resonator evaluation technology with a robust and reliable quartz crystal tuning fork resonator. The sensor offers a high sensitivity and long-term stability and thus is particularly suitable for oil condition monitoring in predictive maintenance programs.

Due to the high measurement rate excellent data quality can be obtained even in unsteady environmental conditions (pressure, temperature, flow).

The ICMS offers digital and configurable analog interfaces for easy and cost-effective integration into existing environments.

# 1 General Specifications

Description	min	typ	max	Unit
Mechanical				
Size (drawings see sec. 8.)		∅30 × 90		mm
Mass		150		g
Mounting		G3/8"		
Torque	31		39	Nm
Operating Conditions				
Tolerated Particle Size			250	μm
Oil Pressure			50	bar
Operating Temperature <sup>1</sup>	$T_{op}$		100	°C
Fluid Temperature <sup>2</sup>	$T_{fluid}$		125	°C
Flow Velocity			20	m/s
Supply				
Voltage	9	24	32	V
Power Consumption				
Analog Outputs unconnected		1		W
Analog Output Driver <sup>3</sup>		$(V_{supply} - V_{out}) \times I_{out}$	1.3	W
Interfaces				
Connector	EN 61076-2-101	M12-8		
Analog Outputs	2 × 4-20 mA	A-coding		
Digital	Modbus RTU			
Conformity				
CE	EN 61000-6-1/2/3/4			
Ingress Protection (M12 mated, 24h)	DIN EN 60529	IP67		
Compliant Fluids				
Mineral and Synthetic Oils				
<i>further approvals on request</i>				

<sup>1</sup>Permissible temperature range of the sensor electronics (housing surface).

<sup>2</sup>Permissible temperature range of the liquid. Be aware that the liquid temperature influences the housing temperature and thus the operating temperature of the electronics.

<sup>3</sup>Temperature derating see Fig 4.

## 2 Measurement Specifications

Unless otherwise noted specifications valid at an ambient temperature of 24°C in reference liquid: Hydraulic oil HLP 32 at 40°C, laminar flow regime.

Description	min	typ	max	Unit
Measurement Range				
Resonator Frequency		20 - 25		kHz
Viscosity (kinematic) $\nu$	1		400	cSt (=mm <sup>2</sup> /s)
Density $\rho$	0.5		1.5	g/cm <sup>3</sup>
Temperature	-40		125	°C
Data Rate		1		1/s
Analog Output 4-20mA				
Accuracy			±1	% FS
Supply Headroom $V_{\text{supply}} - V_{\text{out}}$	5			V
Trueness (according to ISO 5725-1) <sup>1, 2, 3</sup>				
Viscosity $\nu \leq 200$ cSt		±1	±2	% ± 0.1 cSt
$\nu > 200$ cSt			±5	%
Density $\nu \leq 200$ cSt		±0.2	±1	%
$\nu > 200$ cSt			±2	%
Temperature		±0.1	±1	°C
Repeatability (relative standard deviation) <sup>4</sup>				
Viscosity <sup>5</sup> $\nu = 50$ cSt		0.3		%
Density <sup>5</sup> $\nu = 50$ cSt		0.05		%
Temperature		0.02		°C

<sup>1</sup>Maximum permissible deviation between the measured values and reference measurements according to ASTM D7042 in a hydraulic oil HLP 32.

<sup>2</sup>In fluids with pronounced non-Newtonian behavior additional deviations have to be expected.

<sup>3</sup>Custom calibration on request.

<sup>4</sup>Standard deviation for 100 consecutive measurements under constant conditions, data filter disabled.

<sup>5</sup>See Fig. 1, 2, and 3, for information on the influence of the individual parameters.

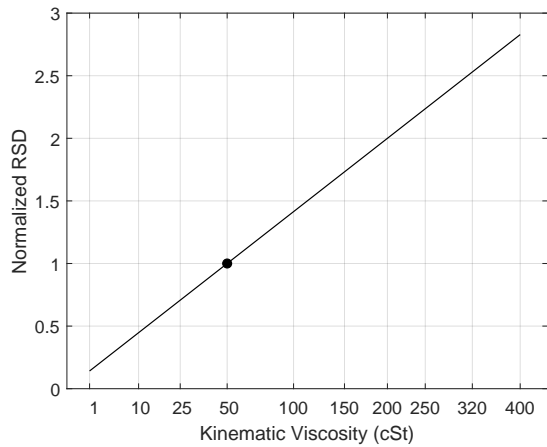

Figure 1: Normalized relative standard deviation (RSD) of viscosity as a function of viscosity. The marker refers to the values in table above.

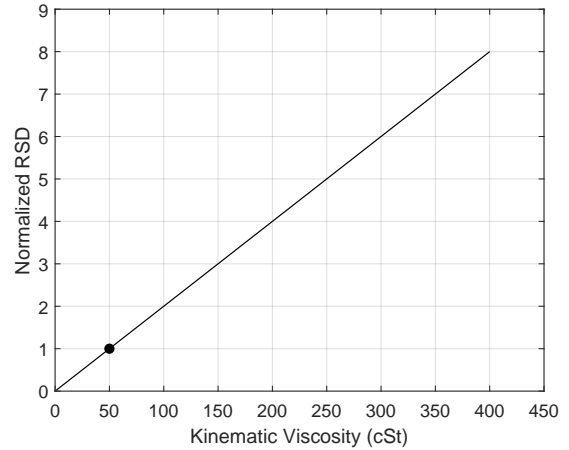

Figure 2: Normalized relative standard deviation (RSD) of density as a function of viscosity. The marker refers to the values in table above.

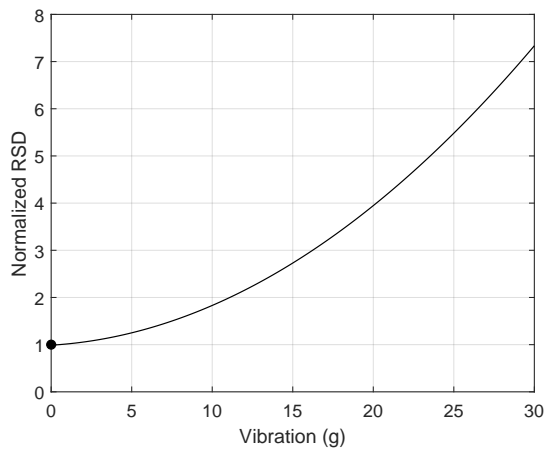

Figure 3: Normalized relative standard deviation (RSD) of viscosity and density as a function of vibration acceleration ( $g_{RMS}$  in all directions). The marker refers to the values in table above.

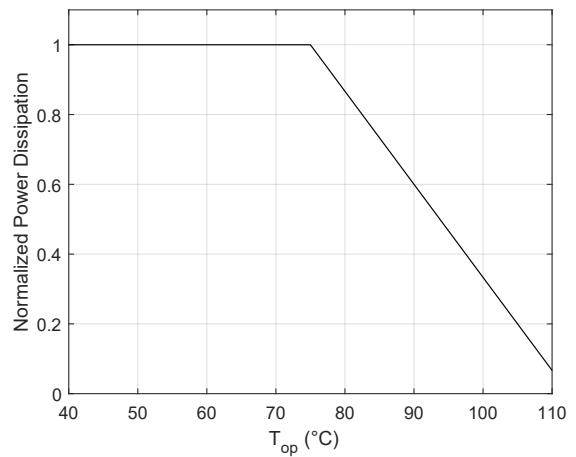
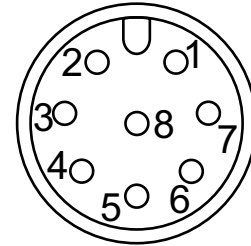

Figure 4: Derating of the power dissipation of the analog output driver.

### 3 Electrical Connections

Power supply and signals share a male M12-8 connector with A-coding according to DIN EN 61076-2-101. Install using shielded cables only.

Pin	Signal	Notes
1	OUT 1	4-20mA output
2	CFG reset	Connect to Ground
3	RS-485 A	Modbus RTU
4	Terminator	Connect to pin 3 for termination
5	RS-485 B	Modbus RTU
6	OUT 2	4-20mA output
7	+24V	Supply
8	0V	Ground



Pin arrangement (sensor side)

The internal 120 Ω resistor for RS-485 bus termination is activated by connecting pin 4 to the RS-485 A line (pin 3). To deactivate termination either connect pin 4 to RS-485 B line (pin 5) or leave it unconnected. Any connection should be as close as possible to the sensor.

### 4 Analog Outputs

The sensor provides two independent analog current loop transmitter outputs (4-20mA). For both outputs, the measured variable as well as the measuring range can be configured by the user (see Sec. 6.4). By default analog output 1 is configured for temperature (-40 .. 125 °C) and analog output 2 is configured for viscosity (0 .. 400 cSt). An invalid measurement result is represented by an output current of 1 mA.

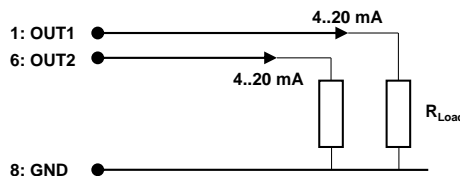

Analog outputs wiring.

Please note that each analog output driver contributes to the total power dissipation of the sensor by  $(V_{\text{supply}} - V_{\text{out}}) \times I_{\text{out}}$ . In order to avoid overheating the tolerated dissipation has a temperature dependent limitation as shown in Fig. 4. It is recommended to reduced the power dissipation by adding external load resistance, especially when the supply voltage is significantly higher than the output voltage of the current transmitter.

### 5 Data Filter

The raw data rate of the sensor is approximately one measurement per second. In order to provide reliable low-noise results in applications with lower data rate requirements, the ICMS provides a moving average filter for all measured parameters. The length of the filter is configurable from 1 to 256 seconds through a Modbus register with a default value set to 60s. Erroneous measurements (such as e.g. out-of-range) are stored in the filter as well but discarded in the averaging process. Therefore, the output of the filter will provide valid results as long as there is valid data in the filter.

## 6 Modbus Interface

Modbus RTU over RS-485 can be used to retrieve measurement results and status information and for configuration of filter settings, analog outputs, and the Modbus interface itself. All data is organized in 16-bit registers using signed or unsigned integer values. Where necessary two registers are combined (MSB first) to represent a 32-bit integer.

The supported Modbus function codes are:

- 3: read holding registers
- 6: write single holding register
- 16: write multiple holding registers

### 6.1 Default Configuration

The default configuration is 19200 Bd, 8 data bits, no parity bit, one stop bit and device address 1. When communicating with the device a timeout value of at least 2s should be used. By default analog output 1 is configured for temperature (-40 .. 125 °C) and analog output 2 is configured for viscosity (0 .. 400 cSt). Please note that all changes to the configuration (except for the Modbus interface) are applied immediately but are only saved permanently when 1 (0x0001) is written to the command register.

### 6.2 Reset to Default Configuration

In case of misconfiguration the sensor can be reset to above factory defaults by applying the following procedure:

1. Connect pin 2 to ground.
2. Power up the sensor properly and wait at least 5 seconds.
3. Connect pin 2 to the supply voltage (nominal +24 VDC, pin 7) for at least 10 seconds.
4. Unpower the sensor.
5. Connect pin 2 to ground and power the sensor again.
6. After restart, the configuration will be reset to factory defaults.

### 6.3 Modbus Register Map

Address		Description	Unit	size words	datatype	r/w
DEC	HEX					
0	0x0000	General Purpose		1	uint16	rw
1	0x0001	HW Revision ID		1	uint16	r
2	0x0002	Serial Number		2	uint32	r
4	0x0004	Firmware Date		2	ulnt32	r
6	0x0006	reserved		1		
7	0x0007	reserved		1		
8	0x0008	Error Count		2	ulnt32	r
<b>Measurement Results</b>						
16	0x0010	Measurement #		2	ulnt32	r
18	0x0012	Viscosity	0.01 cSt	1	ulnt16	r
19	0x0013	Density	0.1 g/l	1	ulnt16	r
20	0x0014	reserved		1		
21	0x0015	reserved		1		
22	0x0016	Temperature	0.01 °C	1	slnt16	r
23	0x0017	Status Code		1	ulnt16	r
24	0x0018	reserved				
25	0x0019	reserved				
26	0x001A	Viscosity	0.1 cSt	1	ulnt16	r
<b>Config Data Block</b>						
32	0x0020	LOCK Register		1	ulnt16	rw
33	0x0021	Command		1	ulnt16	r(w)
34	0x0022	Baud Rate	1 Bd	2	ulnt32	r(w)
36	0x0024	Address		1	ulnt16	r(w)
37	0x0025	Parity / Stop Bits <sup>1</sup>		1	ulnt16	r(w)
38	0x0026	Filter Length		1	ulnt16	r(w)
39	0x0027	reserved		1		
40	0x0028	OUT1_select		1	ulnt16	r(w)
41	0x0029	OUT1_min		1	u/slnt16	r(w)
42	0x002A	OUT1_max		1	u/slnt16	r(w)
43	0x002B	reserved		1		
44	0x002C	OUT2_select		1	uint16	r(w)
45	0x002D	OUT2_min		1	u/slnt16	r(w)
46	0x002E	OUT2_max		1	u/slnt16	r(w)
47	0x002F	reserved		1		

Table 1: Modbus register map.

<sup>1</sup>This register is available since firmware version 2023-01-11.

## 6.4 Description of Registers

### General Purpose

This is an unused register that can be used freely. The content of this register may be altered at reset.

### HW Revision ID

Hardware version of the sensor.

### Serial Number

Serial number of the sensor.

### Firmware Date

Timestamp of the sensor firmware in UNIX time format.

### Error Count

Counter for measurement errors including out-of-range events. At powerup, this value is set to zero.

### Measurement Results

Each measurement is assigned a consecutive number which is reset to 0 at powerup and can be read from the Modbus registers. Measurement results are scaled according to section 6.3 and encoded in signed/unsigned 16-bit integers. Invalid results are indicated by a value of 0xFFFF.

### Status Code

This register is used to report measurement and error/warning conditions. Each bit that is set to 1 indicates a specific condition:

Bit	Description	Possible Reasons
0	No resonance detected	Resonance search is still in progress, Liquid out of measurement range, Sensor damaged or contaminated
1	Out of range	At least one parameter is out of range
2	Frequency controller error	Viscosity or density out of range
3	Noise error	Electromagnetic interference, Very high flow velocity
4	Invalid configuration	Invalid or missing configuration
5	Resonator error	Resonator damaged
6	Temperature sensor error	Temperature sensor damaged
7	Hardware error	Damaged sensor electronics
8	Firmware error	An unspecified firmware error was triggered
9	reserved	ignore
10	Supply voltage too low or too high	Improper or unstable power supply
11	Internal temperature limit	The sensor is operated beyond the thermal specification
12-15	reserved	ignore

Table 2: Interpretation of status code bits.

**Note: If one or more of the above status code bits is set, the measurement results may be invalid or compromised.**



### LOCK Register

Registers of the Config Data Block are prevented from accidental write access by the LOCK register. To enable write mode for the Config Data Block (including the Command register) write 44252 (0xACDC) to the LOCK register. After the configuration is finished set the LOCK register 0 to prevent accidental damage to the configuration.

### Command Register

To permanently save changes write 1 (0x0001) to the Command register. Please note that this operation may take about 1 s. When writing 255 (0x00FF) to the Command register the device is restarted.

### Baud Rate

Baud rate of the Modbus interface. Accepted values are 9600, 19200, and 115200 Bd. Default value: 19200 Bd. Changes are activated after a restart.

### Parity / Stop Bits

Selection of parity bit and stop bits of Modbus interface. The default is no parity bit and one stop bit. Changes are activated after a restart.

Value	Selection
0	no parity / 1 stop bit
1	no parity / 2 stop bits
2	even parity / 1 stop bit
3	even parity / 2 stop bits
4	odd parity / 1 stop bit
5	odd parity / 2 stop bits

Table 3: Selection of Modbus parity and stop bits.

### Address

Device address of the sensor. Default value: 1. Changes are activated after a restart.

### Filter Length

Length of the moving average data filter in the range of 1 to 256. Default value: 60.

### OUT<sub>x</sub>\_select

Selection of parameter that is mapped to analog output x, where x is 1 or 2.

Value	Selection
0	Output disabled
18	Viscosity
19	Density
22	Temperature

Table 4: Selection of analog output parameter.

### OUT<sub>x</sub>\_min

Value that is mapped to 4 mA output current. This value must be scaled and encoded in the same way as the selected measurement parameter (see section 6.3). If the measurement result is lower than this limit, the output remains at 4 mA as long as the result is valid (saturation).

### **OUT<sub>x</sub>\_max**

Value that is mapped to 20 mA output current. This value must be scaled and encoded in the same way as the selected measurement parameter (see section 6.3). If the measurement result is higher than this limit, the output remains at 20 mA as long as the result is valid (saturation).

By default analog output 1 is configured for temperature (-40 .. 125 °C) and analog output 2 is configured for viscosity (0 .. 400 cSt). An invalid measurement result is represented by an output current of 1 mA.

From a valid analog output current  $I_x$  the associated output value  $OUT_x$  can be calculated using this formula:

$$OUT_x = \frac{I_x - 4 \text{ mA}}{16 \text{ mA}} \cdot (OUT_{x_{\max}} - OUT_{x_{\min}}) + OUT_{x_{\min}}$$

## 7 Mounting and Handling

The sensor element of the ICMS is a quartz crystal tuning fork resonator. To protect this resonator from mechanical impacts, the ICMS features a permanent protective cap. The liquid can enter this cap through an opening at the tip and leave through openings at the side.

It is recommended to mount the sensor in a T-fitting (inlet opposite to the sensor and outlet to the side) or a similar setup. For sealing we recommend a bonded seal washer; Torque required for these washers typically is the range of 31 – 39 Nm.

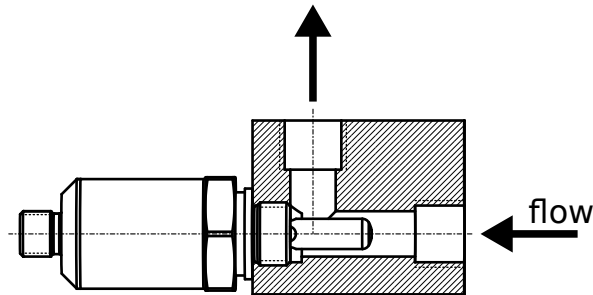

Recommended mounting orientation.

The sensor element of the ICMS is virtually insensitive to mounting orientation, flow direction or pressure. Nevertheless, for optimal performance we recommend considering a few details:

- Air bubbles change the mechanical properties of a liquid and thus influence the measurement. Make sure no air pockets can get trapped at the sensor and potential bubbles are carried away from the sensor by flow or buoyancy. Avoid feeding oil with entrained air to the sensor and be aware that dissolved gases in the oil may form bubbles when pressure is reduced.
- When placing the sensor in a reservoir or a sump the flow rate may be very low. This may lead to extremely slow reaction of the sensor, to residuals influencing the measurement or even clogging the sensor.
- Although the sensor element itself is virtually insensitive to pressure, the viscosity of oil is a function of pressure. The effect of pressure fluctuation on the measurements are generally more pronounced at higher pressure.
- Consider the heat transfer from the liquid to the sensor case when operating at high liquid temperature.
- Laminar flow is required in the vicinity of the sensor. Turbulence is a source of high acoustic energy and can therefore increase the noise of the measurement results or temporarily interrupt the measurement.

If cleaning of the sensor is necessary use suitable solvents (e.g. white spirit or alcohol).

### Do not

- use compressed air as this may damage the resonator permanently due to high flow velocity.
- penetrate the protective cap with any kind of object (e.g. needles or wires).

## 8 Dimensions

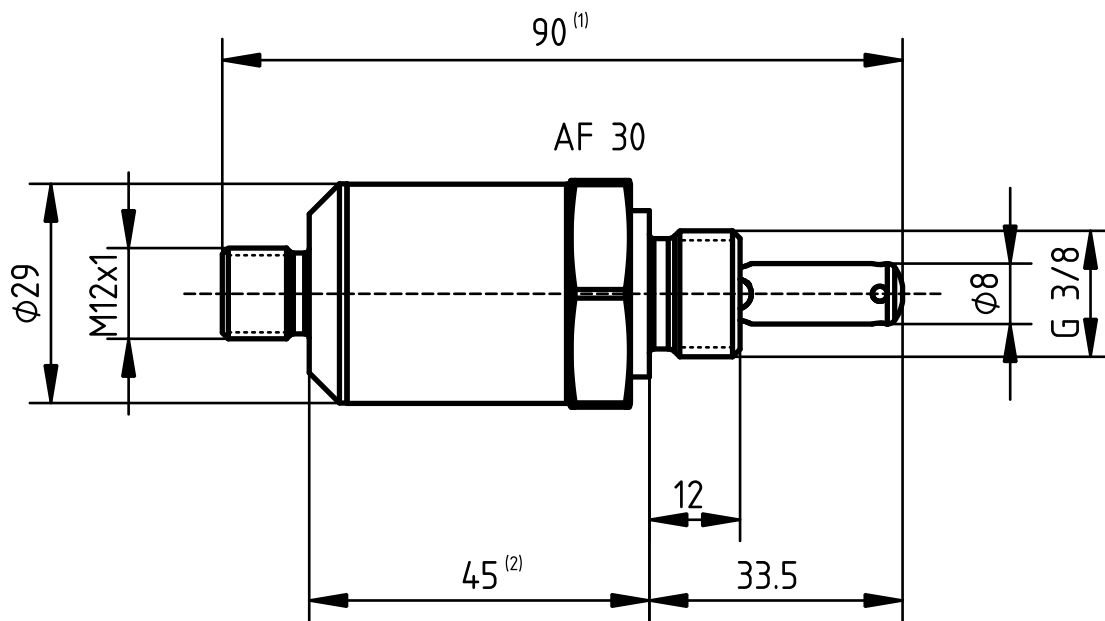

All dimensions in mm, drawing is probably not to scale.

### Revision History

05/2023	Pinout table corrected Specification updated
01/2023	Modbus interface updated
12/2022	Specification updated
07/2022	Specification updated
06/2022	Specification updated
03/2022	Register table added
02/2022	Initial release
09/2021	Preliminary revision

Micro Resonant Technologies GmbH  
A-4040 Linz, Austria  
office@micro-resonant.at

Specifications subject to change without notice.

<sup>1</sup>For hardware revisions 0 and 1 this dimension is 93.4 mm.

<sup>2</sup>For hardware revisions 0 and 1 this dimension is 48.9 mm.